



A1 Series

Users Manual

SOUTH
Target your success

PRECAUTIONS

Congratulations on your purchase of a new A1 total station!

Please read carefully through the User Manual before you switch on the product.

1. Do not collimate the objective lens directly to the sunlight without a filter.
2. Do not stare at the laser beam, or point the laser to the others' eye!
3. Do not store the equipment in extremely high or low temperature.
4. When the equipment is not in use, store it in the case to avoid dust and humidity.
5. If there is a great difference between the temperature in work field or store place, you should leave the equipment in the case until it adapts to the temperature of environment.
6. If the equipment has not been used for a long time, you should remove the battery for separate storage.

The battery should be charged once a month.

7. When shipping the equipment, please place it in the carry case. The cushioned material should be used to cover around the case for support.
8. Clean the exposed optical parts by absorbent cotton or lens-paper only!
9. Clean the surface softly with a woolen cloth. If it gets wet, you should dry it immediately before switch-on.
10. Please check the power-supply, functions, indications and parameters of the equipment goes well before operation.
11. Do not disassemble the total station by yourself. Please contact your authorized agency or South Group when you find the equipment abnormal.

CONTENTS

1. INTRODUCTION.....	1	4.2 Station Height.....	14
1.1 Features.....	1	4.3 Backsight Checking.....	14
1.2 Appearance.....	2	4.4 Resection.....	15
1.3 Measuring Preparation.....	3	4.5 Point to Line.....	16
1.4 Setting Up.....	3	5. COLLECT.....	17
1.5 Battery Information.....	5	5.1 Measure Points.....	17
1.6 Dismounting/Mounting the Tribrach...7		5.2 Distance Offset.....	18
1.7 Eyepiece Focusing.....	7	5.3 Plane Offset.....	19
2. OPERATION.....	8	5.4 Column Offset.....	20
2.1 Symbols.....	8	5.5 MLM.....	21
2.2 Function Keys.....	9	5.6 Line & Extend Point.....	22
3. MEASUREMENT.....	10	5.7 Line & Extend Angle.....	23
3.1 Angle Measurement.....	10	5.8 REM.....	24
3.2 Distance Measurement.....	11	6. STAKE OUT.....	25
3.3 Coordinate Measurement.....	12	6.1 Point Stake-Out.....	25
4. STATION.....	13	6.2 Angle & Distance Stake-Out.....	26
4.1 Known Point.....	13	6.3 Alignment Stake-Out.....	26

6.4 Line Stake-Out.....	27	10.4 Coordinate.....	42
7. JOB.....	27	10.5 Communication.....	42
8. COGO.....	28	10.6 Adjustment.....	43
8.1 Traverse.....	28	10.7 Auxiliary.....	43
8.2 Inverse.....	28	10.8 Initialize.....	44
8.3 Area & Girth.....	29	10.9 About.....	44
8.4 Point-Line Inverse.....	29	11. DATA.....	45
8.5 Intersection – 2 Points.....	30	11.1 Raw Data.....	45
8.6 Intersection – 4 Points.....	32	11.2 Coordinate Data.....	45
8.7 Volume.....	32	11.3 Code Data.....	46
9. ROAD.....	33	11.4 Graphic Data.....	46
9.1 Road Select.....	34	11.5 Data Import.....	47
9.2 H-Alignment.....	34	11.6 Data Export.....	48
9.3 V-Alignment.....	37	12. QUICK SET.....	49
9.4 Road Stake-Out.....	38	12.1 PPM Set.....	49
10. SET.....	39	12.2 Target.....	50
10.1 Unit.....	39	12.3 Tilt-Sensor.....	50
10.2 Angle.....	40	12.4 Measure Mode.....	51
10.3 Distance.....	40	12.5 Laser Plummet.....	51

13. INSPECTION & ADJUSTMENT.....	52	13.8 Constant K.....	58
13.1 Plate Vial.....	52	13.9 Coincidence between Sight of View and Emitting Axis.....	59
13.2 Circular Vial.....	53	13.10 Leveling Screws on Tribrach.....	59
13.3 Tilt-Sensor.....	53	14. SPECIFICATION.....	60
13.4 Reticle Unit.....	54	15. ERROR CODE.....	62
13.5 Perpendicularity between Sight of View & Horizontal Axis (2C).....	55	16. SAFETY GUIDE.....	63
13.6 Compensation of Vertical Index Difference.....	56	16.1 Internal Distance Meter (Visible Laser)	
13.7 Vertical 0 (I Angle)	56	16.2 Laser Plummet.....	65
		APPENDIX – Data Format.....	66

1. INTRODUCTION

1.1 FEATURES

South Android Total Station A1 features open interface, available for any 3rd party software. 5.0-inch capacitive screen with multi-touch technology, ideally suit for your daily task.

- ✧ Integrated CPU, MTK MT6735 quad-core processor boosts speed and performance.
- ✧ Enhanced algorithm, powerful GPU with MaliT720-MP2 3D processor.
- ✧ Multiple data transform. Support wireless Bluetooth, WIFI connection.



1.2 APPEARANCE

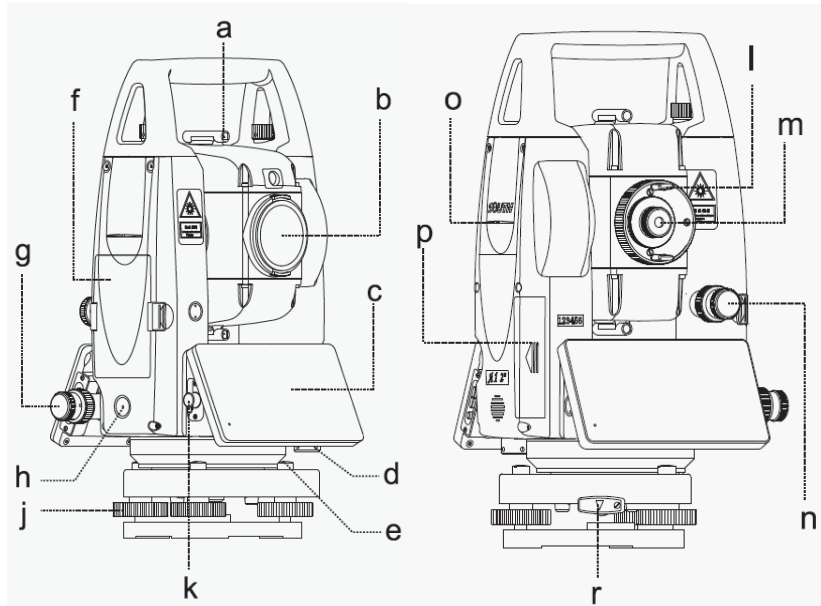

- a Collimator
- b Objective Lens
- c Display Unit
- d T/P Sensor
- e Circle Bubble
- f Battery
- g Horizontal Tangent
- h Trigger Key
- j Leveling Screw
- k RS232 Port
- l Focusing Ring
- m Eyepiece
- n Vertical Tangent
- o Central Mark
- p Comm Port
- r Tribrach Lock

1.3 MEASURING PREPARATION

Unpacking

Lay down the case lightly with the cover upward.
Unlock the case, and take out the instrument.

Storage of Instrument

Cover the cap, place the instrument into the case with the vertical clamp screw and circular vial upwards (lens towards tribrach

1.4 SETTING UP

Setup and Levelling the instrument precisely to ensure the best performance.

Setting up the tripod

- A. Loosen the screws on the tripod legs, pull out to the required length and tighten the screws.
- B. Make the center of tripod and the occupied point approximately on the same plumb line.
- C. Step on the tripod to make sure if it is well stationed on the ground.

Instrument setup

- A. Extended the tripod legs in a stable position.
- B. Place and lock the instrument carefully on the tripod
- C. Turn on the instrument and activate the laser plummet under the Quick-Set. Hold the two free legs which are not fixed on the ground and decide the position to fix according to the laser dot. When the laser dot is roughly on the station point, fix the left 2 legs.

D. Leveling the instrument by circular vial.

- a) Rotate the foot-screw A and B to move the bubble in the circular vial, in which case the bubble is located on a line perpendicular to a line running through the centers of the two leveling screw being adjusted .
- b) Rotate the foot-screw C to move the bubble to the center of the circular vial.

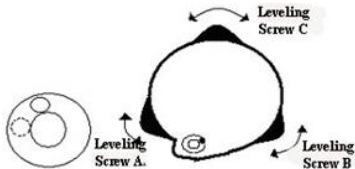

E. Precisely leveling by plate vial

- a) Rotate the instrument horizontally by loosening the horizontal clamp unit and place the plate vial parallel to the line connecting rotating the foot-screw A and B, and then bring the bubble to the center of the plate vial by

rotating the foot-screw A and B.

- b) Rotate the instrument in 90° (100gon) around its vertical axis and turn the remaining leveling screw or leveling C to center the bubble once more.
- c) Repeat the steps and check whether the bubble is correctly centered in all directions.

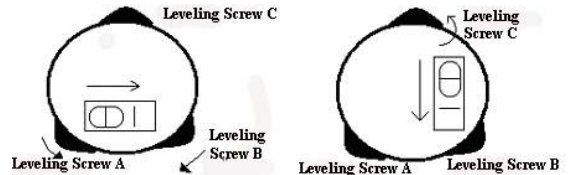

If the laser dot doesn't keep the center position, please slightly loosen the screw under the tripod head and move the instrument (don't rotate the instrument) until the laser dot is on the station point. Tighten the screw and level the instrument again. Repeat these steps until the instrument is precisely centered and leveled.

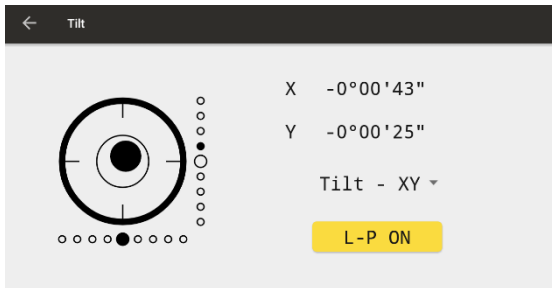

Tips: You can also level the instrument precisely adjust by the E-bubble. When the tilt is over $\pm 3'$, the system will enter to E-bubble interface automatically.

[X]: The compensating value on X direction

[Y]: The compensating value on Y direction

[TILT-OFF]: Turn off tilt sensor

[TILT-X]: Turn on sensor in X direction only

[TILT-XY]: Turn on X&Y sensor in dual directions.

1.5 BATTERY INFORMATION

Inserting Battery

Put the battery into the instrument, push it. Check and insert it correctly to side into the housing.

Replacing Battery

Press the battery lock on both sides, remove the battery. When the remaining voltage is less than one grid, please stop your operation and charge it as soon as possible.

Note: Before remove the battery from the instrument, make sure that the power is turned off. Otherwise, the instrument may be damaged.

Note:

a) The operating time depends on the outside conditions, such as ambient temperature, charging time, the cycles of charging, etc. It is recommended for safety to charge the battery beforehand or to prepare spare full-charged batteries.

b) The remaining voltage of battery shows the power level, regarding to the current measure mode. In normal, the consumption of distance measurement mode is higher than angle measurement mode. When switching the measurement mode from angle to distance in a low battery voltage, it might interrupted the operation.

Charging

The battery must be charged prior to using before the first time operation.

The battery LI-39 should be charged only by the official charger NC-III, which packed together with the instrument. Please connect the power supply in 220V, under $0^{\circ}\sim\pm 45^{\circ}\text{C}$.

When the indicator on the charger is red, the charging process has begun. When indicator turns green, the charging has finished. For safety, please pull out the battery and charger in time.

Note: In order to get the maximum service life, please charge the battery at least once a month.

1.6 DISMOUNTING/MOUNTING THE TRIBRACH

Dismounting

If necessary, the instrument can be dismounted from tribrach. Turn the locking knob about 180° counter-clockwise to disengage anchor jaws, and take off the instrument from tribrach.

Mounting

Insert three anchor jaws into holes of tribrach and line up the directing stub with the directing slot. Turn the locking knob about 180° clockwise to mounting the instrument.

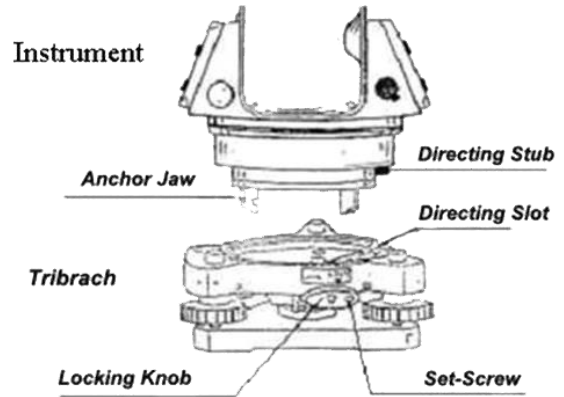

1.7 EYEPIECE FOCUSING

Sight the Telescope to bright place and rotate the eyepiece tube to make the reticle clear. Roughly collimate the target by the top of the

triangle mark on EDM cover.

Rotate the focusing screw on eyepiece to make the image clear.

2. OPERATION

2.1 SYMBOLS

Ang.	Dist	Coord	PSM(0.0) -- PPM(25)
V	:	34°16'02"	MEAS
HR	:	44°38'29"	MODE
SD	:	m	S.0
HD	:	m	
VD	:	m	

Ang.	Dist	Coord	PSM(0.0) -- PPM(25)
V	:	34°16'04"	MEAS
HR	:	44°38'39"	MODE
N	:	m	R.HT
E	:	m	INHT
Z	:	m	STN

V/V%	vertical angle/(gradient display)
HR/HL	horizontal angle right/ left
HD	horizontal distance
VD	vertical difference
SD	slide distance
N	north coordinate
E	east coordinate
Z	elevation coordinate
m/ft	Meter/Feet, distance unit
dms	degree/ minute/ second
Mil/Gon	unit of angle measure
PSM	prism constant value
PPM	atmosphere correction value
PT	point name

2.2 FUNCTION KEYS

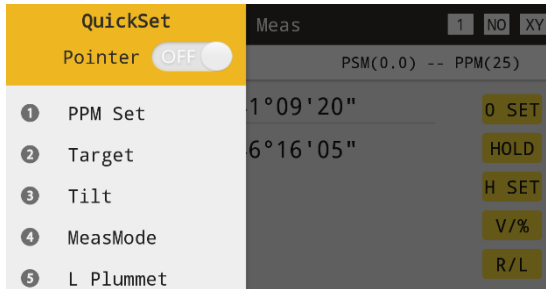

☞ Quick-set

★ **[Quick-Set]:** Including the setting of laser pointer, PPM, target, tilt-sensor, measure mode and laser plummet.

☰ **[Data]:** Including raw data, coordinate data, code and graphic data.

1 **[Mode]:** Including N times, continuous or tracking mode.

OFF **[Target]:** Including Reflector sheet, prism or non-prism mode.

NO **[Electric tilt-sensor]:** X-axis, XY-axis or closed.

3. MEASUREMENT

3.1 ANGLE MEASUREMENT

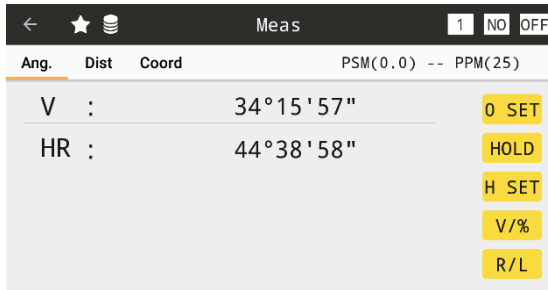

V: Vertical angle

HR/HL: Horizontal right or left

[0 SET]: Set the current horizontal angle to 0. After that the backsight point should be set again.

[HOLD]: Hold the horizontal angle until releasing.

[H SET]: Set the horizontal angle by entered a certain value

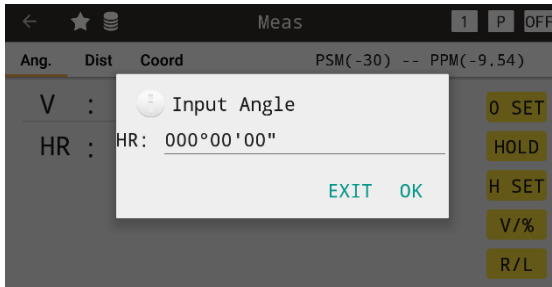

HR: Input the value of horizontal angle

[V/%]: Switch the display of angle between regular vertical angle and slope percentage.

[R/L]: Switch between horizontal right or left.

H-Set

3.2 DISTANCE MEASUREMENT

Ang.	Dist	Coord	PSM(0.0) -- PPM(25)
V	:	34°16'02"	MEAS
HR	:	44°38'29"	MODE
SD	:	m	S.O
HD	:	m	
VD	:	m	

SD: The slide distance.

HD: The horizontal distance.

VD: The vertical distance.

[MEAS]: Measure.

[MODE]: Switch the measure mode

[S.O]: Enter the page of stake out.

HD: 0.000 m
VD: m
SD: m

EXIT OK

Stake-out

[HD]: Input the horizontal distance for stake out point.

[VD]: Input the vertical distance for stake out point.

[SD]: Input the slide distance for stake out point.

3.3 COORDINATE MEASUREMENT

The screenshot shows the 'Meas' screen with the following data:

Ang.	Dist	Coord	PSM(0.0) -- PPM(25)
V :		34°16'04"	MEAS
HR :		44°38'39"	MODE
N :		m	R.HT
E :		m	INHT
Z :		m	STN

The screenshot shows the 'Input Coord' dialog box with the following input fields:

N:	15.000	m
E:	15.000	m
Z:	0.000	m

Buttons: EXIT, OK

☞ Input the coordinate of station point.

N: North coordinate.

E: East coordinate.

Z: Elevation coordinate.

[MEAS]: Measure

[MODE]: Switch the measure mode

[R.HT]: Input the reflector height.

[INHT]: Input the instrument height.

[STN]: Input the coordinate of station

Please redefined the backsight point after station setting.

N: Input North coordinate.

E: Input East coordinate.

Z: Input Elevation coordinate.

4. STATION

Each coordinate computation relates to the currently set station. Please set the station by known points before surveying and stake out,.

4.1 KNOWN POINT

The image shows two screenshots of a surveying application interface. Both screenshots have a dark header with a back arrow, a star icon, a list icon, the text 'Known Pt', and three buttons: '1', 'NO', and 'OFF'.
The top screenshot shows:
- 'Stn' field with '1' and a '+' button.
- 'InHt' field with '0.000' and 'm', and 'R.Ht' field with '0.000' and 'm'.
- A yellow button labeled 'BS PT' followed by a '+' button.
- 'Current' field with '347°33'16"'.
- A red label 'Aim At BS!' and a yellow button labeled 'SET'.
The bottom screenshot shows:
- 'Stn' field with '1' and a '+' button.
- 'InHt' field with '0.000' and 'm', and 'R.Ht' field with '0.000' and 'm'.
- A yellow button labeled 'BS ANG' followed by a '+' button.
- 'Current' field with '347°33'06"'.
- A red label 'Aim At BS!' and a yellow button labeled 'SET'.

There're two methods to set the backsight point: one is by the coordinates of the known point, the other is by the angle of the known point.

Stn: Input the ID of known point, selected from the memory or entered a new point .

InHt: Input the instrument height.

R.Ht: Input the reflector height.

[BS Pt]: Input the ID of backsight point, selected from the memory or entered a new point

[BS ANG]: Input the angle of backsight point.

Current: Display the current horizontal angle.

[SET]: Set the angle of backsight point according to the current input.

4.2 STATION HEIGHT

Calculate the station height by measuring a point with known height.

Field	Value	Unit	Action
Ht	0.000	m	CALL
InHt	0.000	m	
R.Ht	0.000	m	
VD		m	
StnHt(Meas)		m	MEAS
StnHt(Current)	0.000	m	SET

Ht: Input the height of known point, user can selected it from internal memory.

VD: The current vertical angle.

StnHt(Meas): The measured height of station.

StnHt(Current): The current height of station.

[MEAS]: Start to measure

[SET]: Set the measured result as the STN Ht.

4.3 BACKSIGHT CHECKING

Check whether the current angle coincide with the backsight.

Field	Value
Stn Pt	1
BS Pt	
BS	200°00'00"
HA	348°07'13"
dHA	148°07'13"

Stn Pt: The ID of station point.

BS Pt: The ID of backsight point. It will be blank if the backsight angle was input by manually.

BS: The backsight angle.

HA: the current horizontal angle.

dHA: The difference between BS and HA.

[RESET]: Reset the current angle as the backsight.

4.4 RESECTION

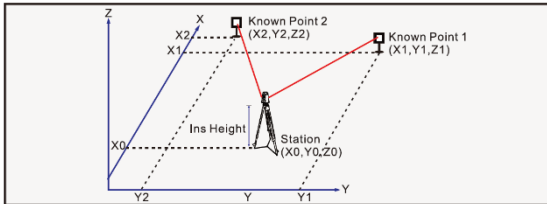

The “Resection” function, also known as Free Station, is used to determine the instrument position from measurements to a minimum of two known points.

Meas	Data	Grav	Resection		
Pt	N	E	Z	HA	
1	15.000	15.000	0.000	352° 14	

MEAS
CALC

☞ The list of measured known points.

Note:

a) If the angle between the first measurement point and the second one is too small or too large, it will influence the geometrical accuracy of calculation result. So selecting a geometrical graphic with good structure is important.

b) The calculation requires at least three angle data or two distance data.

c) Basically, the station height is calculated by the distance data. If the distance data was not carried out, the height will be determined by the angle of known point.

The standard deviations and residuals for accuracy assessments are provided.

Resection 1 NO OFF

Pt 2 +

R.Ht 1.500 m

HA

VA

SD m

ANG.

ANG & DIST

DONE

≡ The measurement for known points

Pt: Input the ID of known point.

R.Ht: Input the reflector height.

HA: The measured result of horizontal angle.

VA: The measured result of vertical angle.

SD: The measured result of slide distance

[ANG.]: Only angle measurement.

[ANG&DIST]: Angle & distance measurement.

[DONE]: Save the result and back to the point list.

4.5 POINT TO LINE

Pt to Line 1 NO OFF

InHt 0.000 m

R.Ht 1.500 m

A-HD 0.513m

B-HD 0.518m

MEAS

MEAS

NEXT

Pt to Line 1 NO OFF

Stn

Aim At BS PtB!

N	0.000 m	BS Ang	0°00'00"
E	0.000 m	Azimet	18°32'55"
Z	0.000 m		

SET

Measure 2 points as A and B, click [next] to calculate the HD/VD/SD between A and B.

Instrument will establish a new coordinate system automatically, click [SET] to set the station.

5. COLLECT

5.1 MEASURE POINTS

It included not only measure and record, but also the point coding and linking in graphic display.

The screenshot shows the 'MeasPt' application interface. At the top, there is a navigation bar with a back arrow, a star icon, a menu icon, and the text 'MeasPt'. To the right of the text are three buttons: '1', 'NO', and 'OFF'. Below the navigation bar are three tabs: 'Meas', 'Data', and 'Grap'. The 'Meas' tab is selected. The main area contains a form with the following fields and controls:

HA:	337°06'20"	Pt	a1	<input type="button" value="DIST"/>	
VA:	69°42'11"	Code	<input type="text"/>		
HD:		m	Link	<input type="text"/>	<input type="button" value="SAVE"/>
VD:		m	Close	<input type="text"/>	
SD:		m	R.Ht	1.500	m

HA: The current horizontal angle.

VA: The current vertical angle.

HD: The measured horizontal distance.

VD: The measured vertical distance.

SD: The measured slide distance.

Data: Show the data of saved points.

Grap: Show the graphic data of saved points.

Pt: Input the ID of point. It will add "1" automatically on the point name in each time.

Code: Input or select the code.

Link: Input the ID of known point, the system will create a line from the known point to current point, and the line will display in graphic.

R.Ht: The reflector height.

[DIST]: Start to measure distance.

[SAVE]: Save the previous result. If the distance measurement was not carried out, the system will save the current angle result only.

[ALL]: Measure and save.

5.2 DISTANCE OFFSET

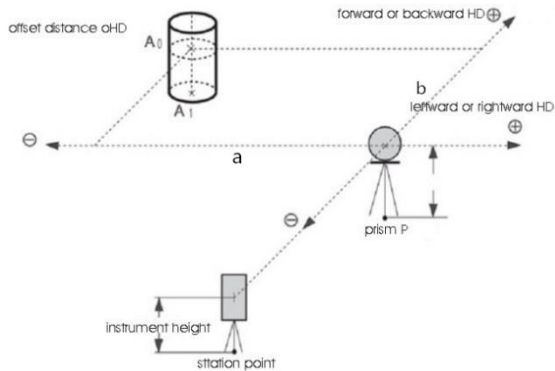

The distance offset calculates from measurement or coordinates longitudinal, parallel offset and height differences of the target point relative to the known point.

Note: All directions are correspondent to the visual side of operator.

← ★ 🗄
DistOffset 1 NO OFF

Meas
Data
Grap

Pt ty1

Code R.Ht 1.500 m

L R 0.000 m
 Fw Bw 0.000 m MEAS
 Up Dn 0.000 m ALL

Pt: Input the ID of point.

Code: Input or call up the code.

R.Ht: Reflector height.

[L][R]: The lateral deviation in left or right

[Fw][Bw]: Difference in length.

[Up][Dn]: The altitude deviation in upward or downward

[MEAS]: Start to measure.

[ALL]: Measure and save.

5.3 PLANE OFFSET

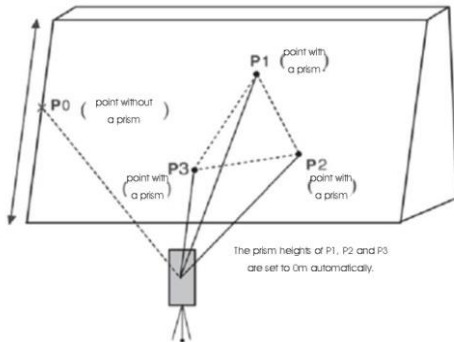

Consider that Point P0 is on the edge of a plane, which cannot be measured directly through non-reflector mode.

Measure P1/P2/P3, the three random prism points to defines a plane. Then aim at Point P0, it will calculate the coordinate automatically.

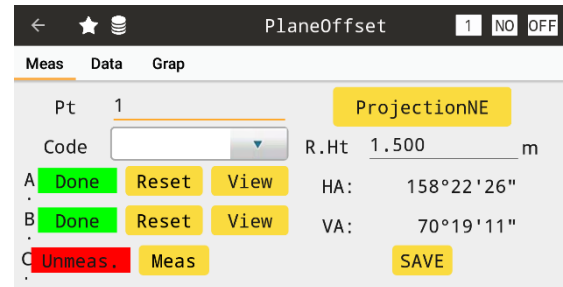

[Meas]: Measure the point.

[Reset]: Re-measure the point.

[View]: View the result.

[SAVE]: Save the calculation result.

HA: The current horizontal angle.

VA: The current vertical angle.

[GraProjec.NE]: User can choose the graphic projection ways in NE/ZE/ZN according to the specific circumstances.

5.4 COLUMN OFFSET

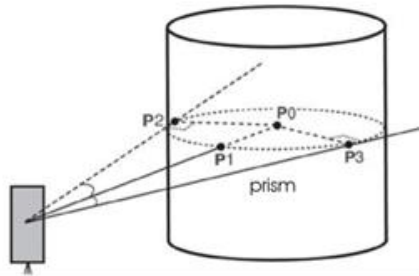

Column offset is widely used in measuring a hidden point that is not directly visible, for example the center of column as picture shown.

Point P1 is the intersection between the station and column, P2 and P3 are the left and right edge points of the cylindrical diameter.

The equipment will calculate the 3D coordinate of point P0 automatically.

ColumnCen. 1 NO OFF

Meas Data Grap

Pt _____

Code _____ R.Ht 1.500 m

Dire.A **OK** HA: 158°21'39"

Dire.B **OK** HA: 158°21'39"

Center **DIST** HD: m

DireA: Collimate the side of column.

DireB: Collimate the other side of column.

Center: Collimate the center and measure.

[OK]: Angle of Direction A/B has been set.

[ANG.]: Re-measure the angle.

[DIST]: Start to measure the center point.

[RESET]: Re-measure the distance.

[SAVE]: Save the measurement result.

5.5 MLM (TIE DISTANCE)

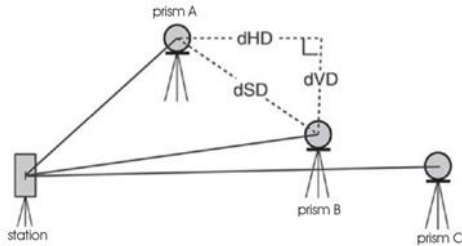

MLM function is mainly used to compute the HD/ VD/ SD/ azimuth between two target points. The coordinate of points can be selected from the memory, entered by manual or measured directly.

The user can choose between two methods:

1. MLM (A-B, A-C), lock the start point
2. MLM (A-B, B-C), unlock the start point.

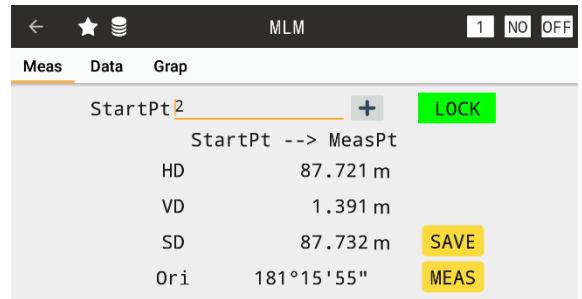

StartPt: Entered or selected a start point

HD: The horizontal distance between two points.

VD: The vertical distance between two points.

SD: The slide distance between two points.

Ori: The bearing angle between two points.

[LOCK]: Lock the current start point, if not, the start point would be the last measured point.

[SAVE]: Save the current result.

[MEAS]: Start to measure.

5.7 LINE & EXTEND ANGLE

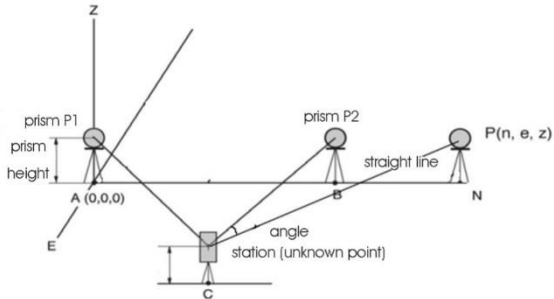

The extension function computes extend point from the base line, calculate the unknown coordinate from two known points and the azimuth.

Known:

P1, start point

P2, end point

Azimuth between station and extend point P

Unknown:

P, Extend point

ExtendAng 1 NO OFF

Meas	Data	Grap
Pt	Code ▼ R.Ht 1.500 m	
HA:	320°30'07"	VA: 44°23'25"
P1	m	MEAS VIEW
P2	m	MEAS VIEW
Azi.		MEAS SAVE

HA: The current horizontal angle.

VA: The current vertical angle.

Pt P1: The slide distance to the first point.

Pt P2: The slide distance to the second point.

Azi: Azimuth between station and extend point.

[MEAS]: To measure the first or second point.

[VIEW]: To view the measurement result.

[SAVE]: Save the extension point.

5.8 REM

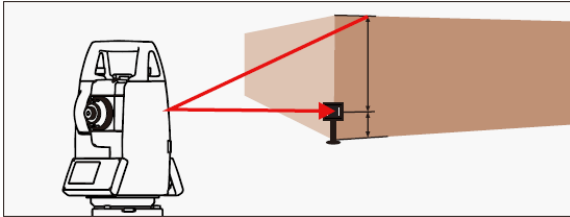

The points directly above the prism can be determined without a reflector at the target point.

When you need the information of a target hang in the air, REM can help you measure the point without a reflector.

In the power industry, this function can be used to measure the height of transmission cable.

← ★ [Menu] REM		1 NO OFF
VA	71°43'38"	
dVD	5.033 m	
R.Ht	1.500 m	
VA	40°39'09"	ANG.
HD	1.628 m	ANG & DIST

VA(the first line): Current vertical angle.

dVD: Vertical difference between measured point and target.

R.Ht: Reflector height.

VA: Vertical angle of measured point.

HD: Horizontal distance of measured point.

[ANG.]: Measure the VA.

[ANG & DIST]: measure the VA and HD.

6. STAKE OUT

6.1 POINT STAKE-OUT

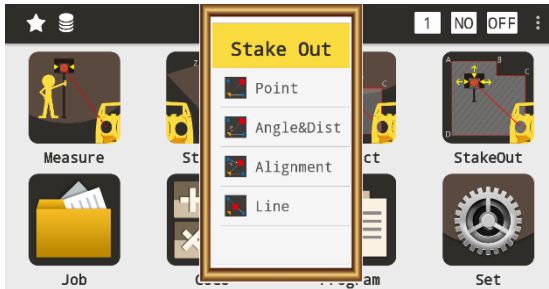

The menu of Stake-out

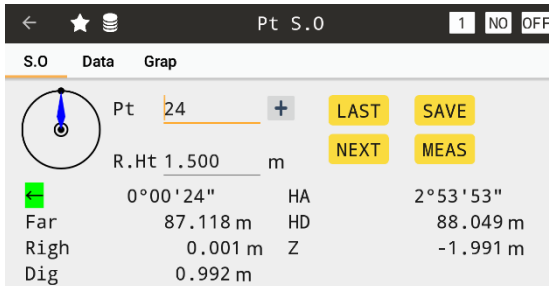

The guidance of Stake-out

Setting out the coordinates from memory or manually entered

Pt: ID of the stake-out point.

R.Ht: Reflector height

[LAST]: Select the last stakeout point

[NEXT]: Select the next stakeout point.

[SAVE]: Save the current stake-out point

[MEAS]: Select the next stakeout point.

←/→: Direction to rotate the instrument.

Far/Near: Guide to move forward or backward.

Left/Right: The deviation from the target

Fill/Dig: Guide to move upward or downward.

HA: Horizontal angle of the stake-out point.

HD: Horizontal distance of the stake-out point.

Z: Elevation of stakeout point.

6.2 ANGLE & DISTANCE STAKE-OUT

The screenshot shows the 'AngDistS.0' interface. At the top, there are navigation icons (back, star, list) and the title 'AngDistS.0' with status indicators '1', 'NO', and 'OFF'. Below the title are tabs for 'S.O', 'Data', and 'Grap'. The main area is divided into two columns. The left column contains a circular diagram with a blue arrow pointing up, a 'MEAS' button, a 'SAVE' button, a blue arrow pointing right, and the value '0°00'01"'. Below this are labels 'Near', 'Left', and 'Fill' with corresponding values: '-24.522 m', '0.000 m', and '-10.101 m'. The right column contains labels 'R.Ht', 'HA', 'HD', and 'Z' with values: '1.500 m', '150°00'00"', '25 m', and '10 m'.

Field	Value	Unit
R.Ht	1.500	m
HA	150°00'00"	
HD	25	m
Z	10	m
Near	-24.522	m
Left	0.000	m
Fill	-10.101	m

Stake-out the points by entered the value of angle offset (HA), longitudinal offset (HD) or height offset (Z)

6.3 ALIGNMENT STAKE-OUT

The screenshot shows the 'Alignment S.0' interface. At the top, there are navigation icons (back, star, list) and the title 'Alignment S.0' with status indicators '1', 'P', and 'OFF'. Below the title are tabs for 'S.O', 'Data', and 'Grap'. The main area contains labels 'Pt', 'Azimuth', 'HD', and 'VD' with values: an empty field with a '+' button, '000°00'00"', '0.000 m', and '0.000 m'. A 'NEXT' button is located at the bottom right.

Field	Value	Unit
Pt		
Azimuth	000°00'00"	
HD	0.000	m
VD	0.000	m

Stake-out the points by entered the value of azimuth, longitudinal offset (HD) and height offset (VD)

Find further details on "Point Stake-out"

6.4 LINE STAKE-OUT

Line S.0 1 NO OFF

S.0 Data Grap

St Pt 10 +

End Pt 11 +

L R 2 m

Fw Bw 2 m

Up Dn 5 m

NEXT

It will calculate the coordinates of the stake-out point through two known points (St Pt and End Pt) and the offset distance (left or right, forward or backward, up or down) based on the line which is formed by the known points

Find further details on "Point Stake-out"

7. JOB

JobList

default	18-09-10 15:29:18
Job18-12-03	10:20:59 18-12-03 10:21:00

+

JobList

New Job

Name Job18-12-07 15:20:31

Edit

Note

CANL OK

+

Press the information key on the right corner to create or delete the job.

8. COGO

8.1 TRAVERSE

← ★ 🗄 Traverse 1 NO OFF

Calc Grap

StartP		+	Result
St. Ang	000°00'00"	N	m
Turn	000°00'00"	E	m
HD	0.000 m	Z	m
VD	0.000 m		

SAVE CALC

Calculate the coordinates of point with a known point, based on the direction and distance offset

St Pt: Start point. Input a known point

St.Ang: Azimuth of start point

Turn: The turning direction of start point.

[SAVE]: Save the calculation result

[CALC]: Calculate the coordinate

8.2 INVERSE

← ★ 🗄 Inverse 1 NO OFF

Inv. Grap

StartP		+
End Pt		+
HD	m V%	
SD	m Ang.	
VD	m	

CALC

Calculate the relationship between two points

St Pt: Start point.

End Pt: End point.

HD: Horizontal distance between two points.

SD: Slide distance between two points

VD: Vertical difference between two points.

V%: Slope of two points.

Ang.: Angle between two points.

[CALC]: Calculate

8.3 AREA & GIRTH

Area	Result	Grap
Name	N	E
22	100.000	15.000
23	102.000	18.000
24	102.936	19.452

Add>> + ↑ ↓ Del. Calc

Calculate the area and perimeter of known points. The added points will be displayed on the list

[ADD] or **[Insert]**: Add or insert points from the memory. Click to switch between add and insert.

[Del]: Delete a chosen data on the list

[Calc]: Calculate

8.4 POINT-LINE INVERSE

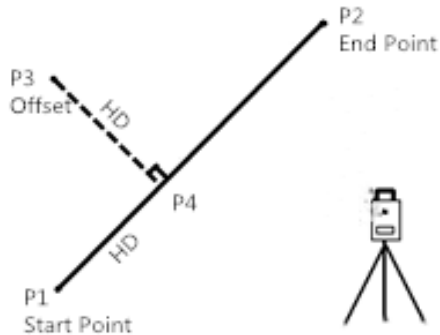

Inv.	Result	Grap
St P1	<input type="text"/>	+
End P2	<input type="text"/>	+
Devi. P3	<input type="text"/>	+

CALC

Input or select the points from the memory

Defined a line between two points, P1 and P2, the offset point P3 is perpendicular to this line. The system will calculate the HD from start point P1 to orthogonal point P4, and from offset point P3 to orthogonal point P4

← ★ 📁
Pt-L Inver
1 NO OFF

Inv.	Result	Grap
N:	101.922	m
E:	14.744	m
Z:	0.000	m
P1 to P4 (HD):	1.939	m
P3 to P4 (HD):	2.397	m

PtName P4

Code: SAVE

↩ the result.

8.5 INTERSECTION-2 POINTS

According to the coordinate of two start points, and the relationship (by azimuth, by distance or both) to calculate the coordinate of intersection point. The points can be selected from the memory, entered by manual or measurement.

1. Calculate the intersection by Azimuth & Distance

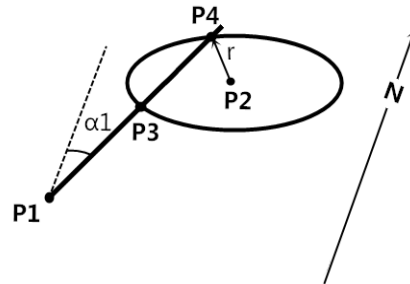

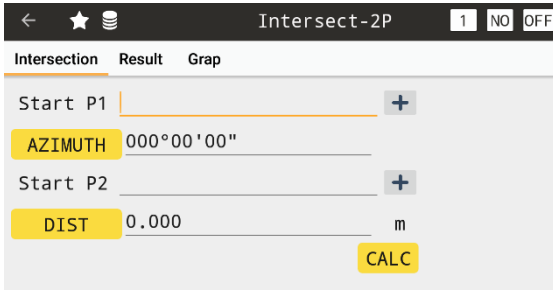

the intersection by azimuth and distance

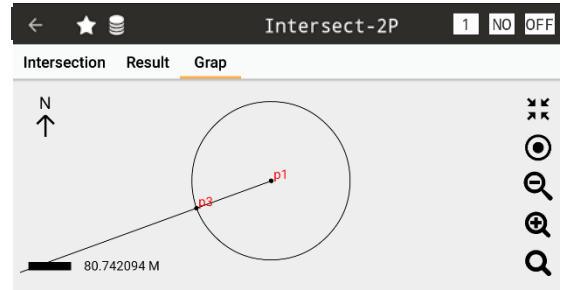

the intersection result in graphic.

2. Calculate the intersection by Azimuth

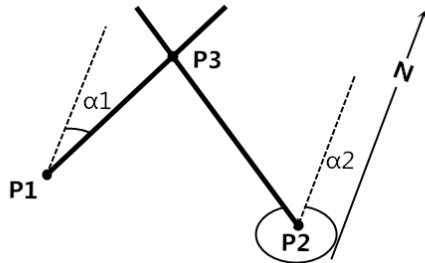

3. Calculate the intersection by Distance

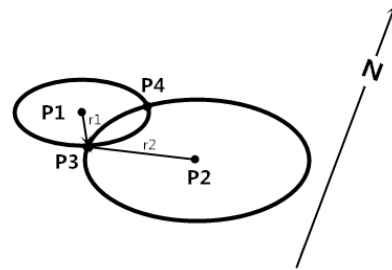

8.6 INTERSECTION-4 POINTS

< ★ ☰ Intersect-4P 1 P OFF

Intersection	Result	Grap
Start P1	<input type="text"/>	<input type="button" value="+"/>
End P2	<input type="text"/>	<input type="button" value="+"/>
Start P3	<input type="text"/>	<input type="button" value="+"/>
End P4	<input type="text"/>	<input type="button" value="+"/>

Calculate intersection point of two lines which are formed by four points

St P1/End P1: The start/end point of Line 1

St P2/End P2: The start/end point of Line 2

[CALC]: Calculate the coordinate of the intersection point.

[SAVE]: Save the coordinate

8.7 VOLUME

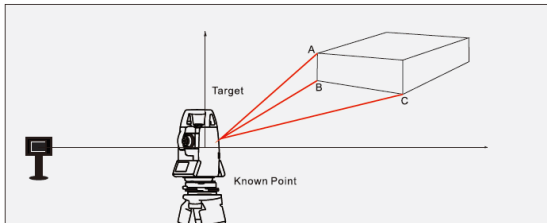

The system will create a triangulation network based on the points in the list, and take the reference height as the reference plane to calculate the volume.

No.	Name	N	E	Z
1	1	15.000	15.000	0.000
2	22	100.000	15.000	0.000
3	22	100.000	10.000	0.000

Refer.Ht	m	ADD ALL	DEL. ALL
St Pt	End Pt	MULTI	DEL.
SinglePt	+	ADD PT	CALC

☞ the calculation result of volume.

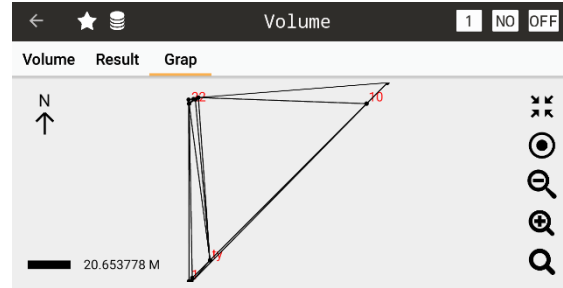

☞ the graphic result of volume.

9. ROAD

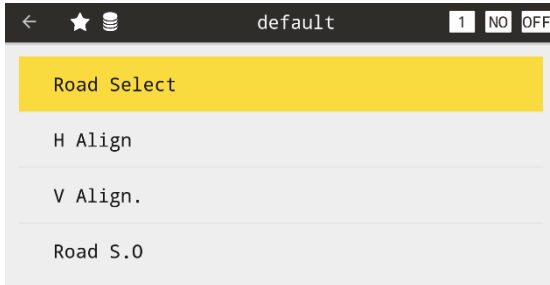

Road Program in AI system, calculate the target as a composite curve which might including the elements of straight line, transition curve and circular curve. The system will stake-out the designed road based on the pile number and deviation value

☞ the Road menu

9.1 ROAD SELECT



Select a road as the current job. Each road included two parts,

Press **[+]** to create a new job. You can also edit or delete the current job in job list

☞ job list

9.2 H-ALIGNMENT

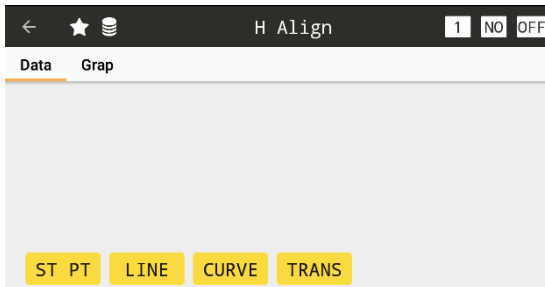

The horizontal alignment including the elements of start point, straight line, circular curve and transition curve.

Click each item to add the elements based on the design

☞ Element list of horizontal alignment

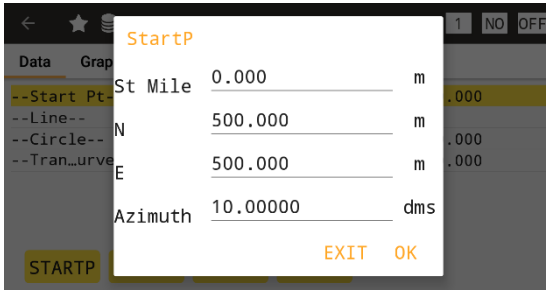

Input the parameter of start point

St Mile: entered the mile of start point

N: North coordinate of start point

E: East coordinate of start point

Azimuth: Azimuth of start point

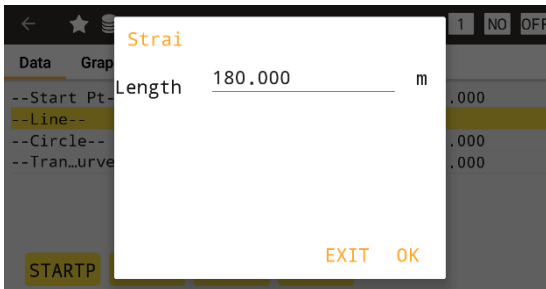

Input the parameter of straight line

Length: entered the length of straight line.
the value should > 0.

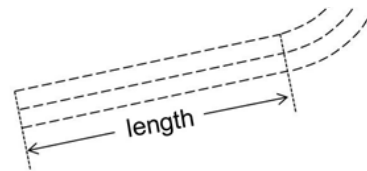

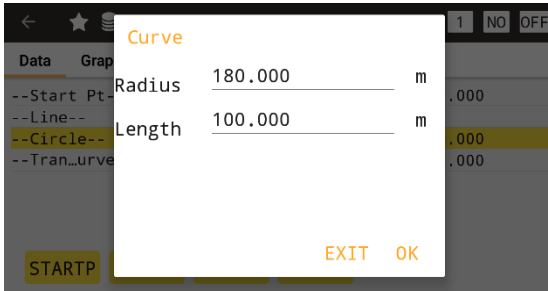

☞ *Input the parameter of circular curve*

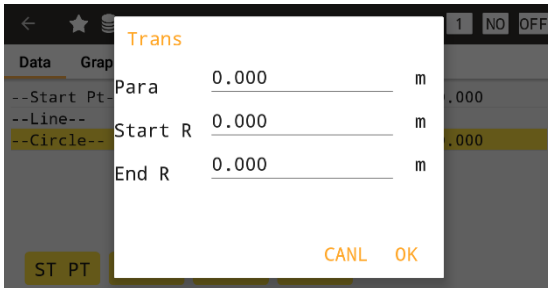

☞ *Input the parameter of transition curve*

R: entered the radius of curve.

The positive value means the road is turning right, the negative value means left.

Arc: the length of curve, the value should > 0 .

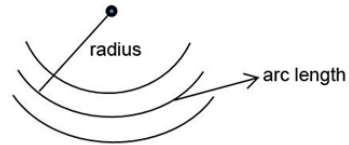

Para: Input the parameter, the positive value means turning left, negative value means turning right.

Start R: Input the start radius R_1

End R: Input the end radius R_2

While one side of the radius is ∞ , for convenience, user can input 0.

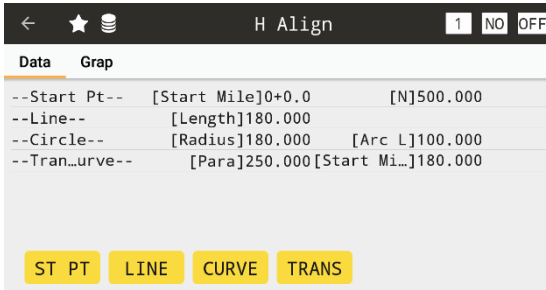

☞ Element list of horizontal alignment, click each item to edit or delete the data.

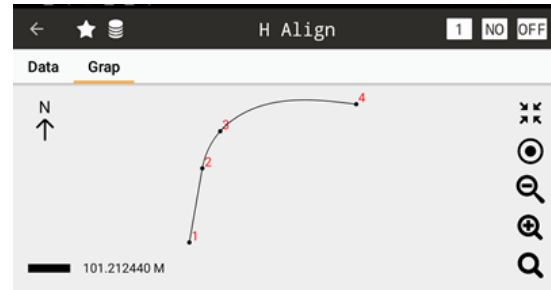

☞ Graphic display of the horizontal alignment.

9.3 V-ALIGNMENT

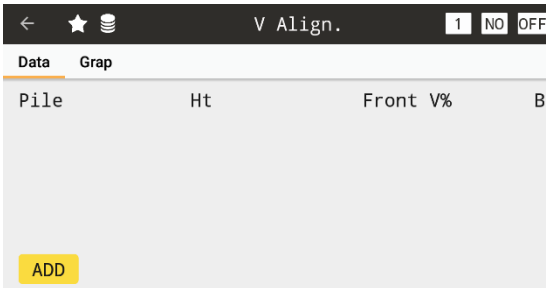

The vertical alignment is composed by the intersection points which including pile number, elevation and length of the curve.

The length of curve, for start and end point must be zero.

☞ Element list of vertical alignment

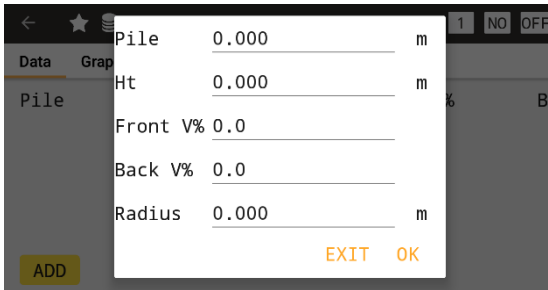

Input the parameter of vertical elements

[ADD]: Add a new element of vertical alignment.

Pile: The pile ID of changing point

Ht: The height of changing point

Front V%: The vertical slope between current point to the last point.

Back V%: The vertical slope between current point to the next point.

R: The radius, distance between two points.

9.4 ROAD STAKE-OUT

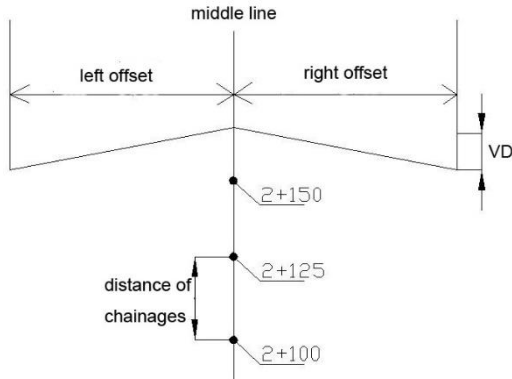

Please confirmed that the station has been set, also the horizontal and vertical alignment has been defined correctly before stake-out.

← ★ 🗄 Road S.O 1 NO OFF

St Mile 0.000 m

Step 10.000 m

Pile Deviation

L R 0.000 m

Up Dn 0.000 m

NEXT>

⇒ Please check Chapter 6 Stake-out for further guidance.

St Mile: The start position of stake-out

Step: The increased or decreased mile in each step.

L/R: The left or right offset from the middle line of the road.

Up/Dn: The elevation offset of the design point to the middle line.

[NEXT]: Go for next step (stake-out).

10. SET

10.1 UNIT

← Unit ⋮

Unit	Angle Degree
Angle	
Distance	Dist. M
Coordinate	Temp. °C
Comm.	
Adjustment	Pressure hPa

Angle: Set the angle unit, among degree, gon, mil

Dist.: Set the distance unit, M (Meter) or Ft (Feet)

Temp.: Set the temperature unit, °C or °F

Pressure: Set the pressure unit, hPa, mmHg, inHg.

10.2 ANGLE

← Angle	
Unit	Ang.
Angle	V0 H0
Distance	Tilt-Comp OFF
Coordinate	
Comm.	
Adjustment	

V0: Set horizontal zero or vertical zero.

Tilt-comp: On or off the tilt compensator.

Press the information button on the right corner to set the current setting as default. The new job will follow the same settings.

10.3 DISTANCE

← Distance	
Unit	Para
Angle	Scale 1.0
Distance	Ht 0.000m
Coordinate	
Comm.	K Off
Adjustment	T-P Set

Para

Scale: Set the scale factor of measurement.

Ht: Set the height of the station.

K: Set the correction parameter of atmosphere refraction modulus and earth curvature radius.

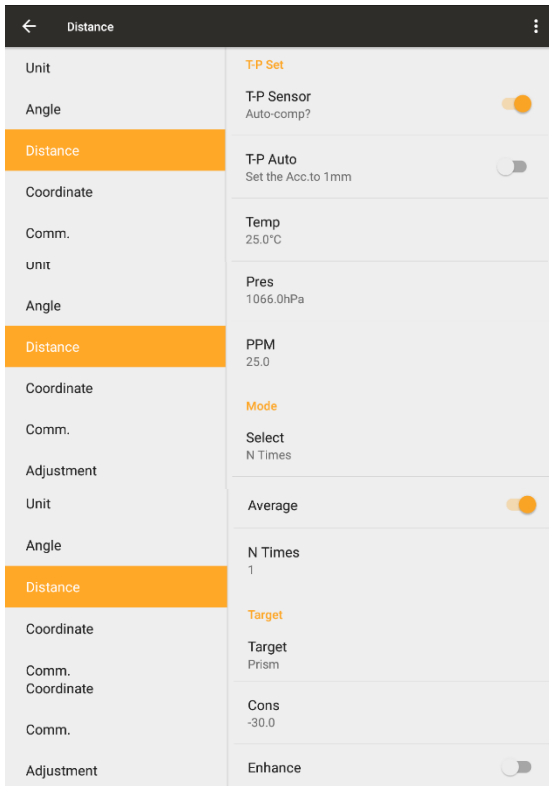

T-P Set

T-P Sensor: On/off the temperature & pressure sensor.

T-P Auto: On/off the T-P auto correction

Temp: Set the current temperature.

Pres: Set the current pressure.

PPM: Set the atmosphere correction value.

Mode

Select: N times, continuous or tracking.

Average: calculate the average value

N times: Set the measure times, maximum 20.

Target

Target: Set the target among prism, reflector sheet and non-prism.

Cons: Set the constant of prism

Enhance: Enhance the measure range (Single prism up to 5000m, triple prism up to 6000m)

10.4 COORDINATE

← Coordinate	
Unit	Order N-E-Z
Angle	
Distance	HL/HR HL/HR Same Result
Coordinate	
Comm.	
Adjustment	

Order: the order of coordinate display. By N-E-Z or E-N-Z.

HL/HR: Set whether the coordinate value is relative to instrument's HL or HR, if not, the measurement results on both left face and right face are the same.

10.5 COMMUNICATION

← Comm.	
Unit	Comm OFF
Angle	
Distance	BaudRate 9600
Coordinate	
Comm.	Bit 8Bits
Adjustment	Parity Odd
Comm.	
Adjustment	Stop 1Bit

Comm: On or off the comm port.

Baud Rate: Set the baud rate of communication.

Bit: Set the bit of communication port, 8 or 7 bits.

Parity: set the parity bit of communication, odd/ even/ none.

Stop: set the stop bit of communication, 1 or 2 bits.

10.6 ADJUSTMENT

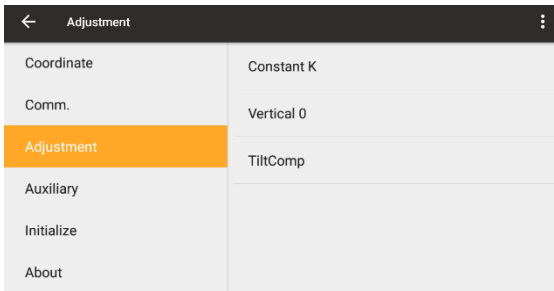

Constant K: Set the constant K of prism or non-prism mode.

Vertical 0: The adjustment of vertical difference (the so-called i-angle). This item must be adjusted when you finished the compensator and crosshair adjustment.

TiltComp: The adjustment of electronic tilt-sensor, also called E-bubble.

10.7 AUXILIARY



Retic.Illu: On or off the reticle illumination.

10.8 INITIALIZE

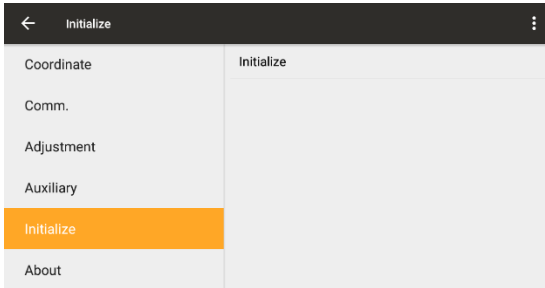

Initialize: Initialize the parameter/ settings back to the factory mode.

10.9 ABOUT

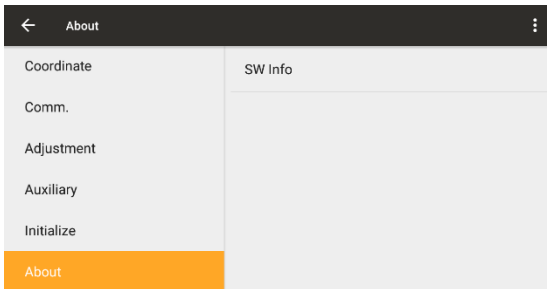

SW Info: View the software information, including the software version, model name, SN and device ID. Also you can check the version of mainboard, EDM, compensator and T-P sensor.

11. DATA

11.1 RAW DATA

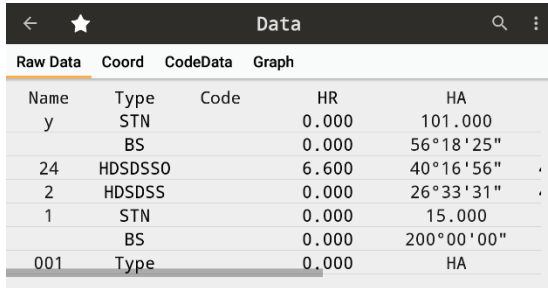

Name	Type	Code	HR	HA
y	STN		0.000	101.000
	BS		0.000	56°18'25"
24	HSDSSO		6.600	40°16'56"
2	HSDSS		0.000	26°33'31"
1	STN		0.000	15.000
	BS		0.000	200°00'00"
001	Type		0.000	HA

View the raw data. For further data format, please check the Appendix in the last page.

 Clear the data list, import or export the raw data.

 Search the point from the data list.

11.2 COORDINATE DATA

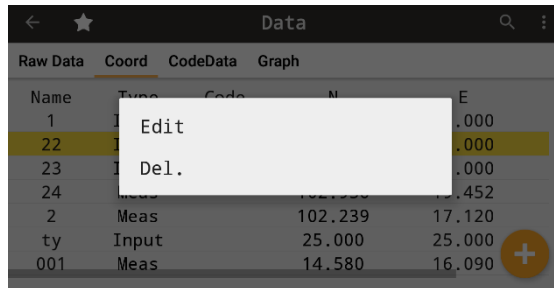

Name	Type	Code	N	E
1				.000
22				.000
23				.000
24				.452
2	Meas	102.239		17.120
ty	Input	25.000		25.000
001	Meas	14.580		16.090

View the coordinate data.

Click the point in once to edit or delete the data.

 Clear the data list, import or export the raw data.

 Search the point from the data list.

11.3 CODE DATA

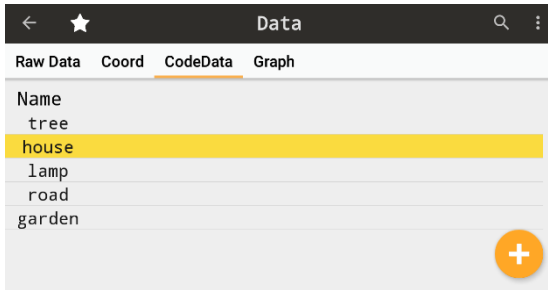

View the code data.

Click the code in once to edit or delete the data.

 Clear the data list, import or export the raw data.

 Search the point from the data list.

11.4 GRAPHIC DATA

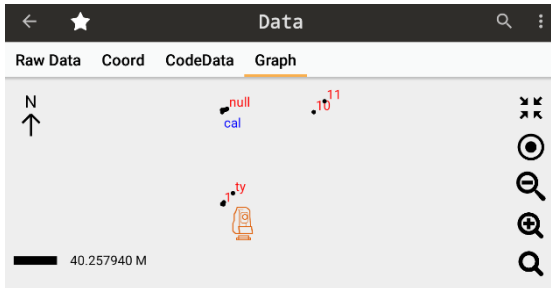

View the graphic data.

 Sort and filter the points. By point name, by code or line.

11.5 DATA IMPORT

The screenshot shows the 'Data' application interface. At the top, there is a navigation bar with a back arrow, a star icon, the title 'Data', a search icon, and a menu icon. Below the navigation bar is a table with four columns: 'Raw Data', 'Coord', 'CodeData', and 'Graph'. The table contains several rows of data. A context menu is open over the table, showing three options: 'Clear', 'Import', and 'Export'.

Raw Data	Coord	CodeData	Graph
Name	Type	Code	HR
y	STN	0.000	
	BS	0.000	
24	HDSOSSO	6.600	40°18'30"
2	HDSOSS	0.000	26°33'31"
1	STN	0.000	15.000
	BS	0.000	200°00'00"
001	Type	0.000	HA

Click **[Import]** and **[FILE]** to select the file from internal memory or flash disk.

The screenshot shows the 'Import' dialog box. It has a title bar with a back arrow and the word 'Import'. The dialog contains the following fields and options:

- Location: /storage/sdcard0/total...
- Data Source: TXT (*.txt) (dropdown menu)
- Data Type: Coord. (dropdown menu)
- Format: Pt,N,E,Z,Code (dropdown menu)
- Two yellow buttons at the bottom: 'FILE' and 'IMP.'.

Choose the data type (Coordinate/ Code data) and format (the display order of point name, code, N, E, Z) you want, then click **[IMP.]** for import.

11.6 DATA EXPORT



Click **[Export]** to choose the location (RAM/ Comm or U-disk), data type (Coordinate/ Code/ Raw Data) and the format you want, then click **[EXP.]** for export.

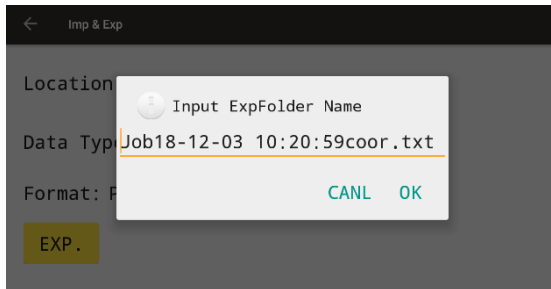

Entered the name and save the file.

AI is available to transfer the data by Bluetooth. Check [Settings], [Bluetooth] in Android system to pair the devices.

12. QUICK-SET ★

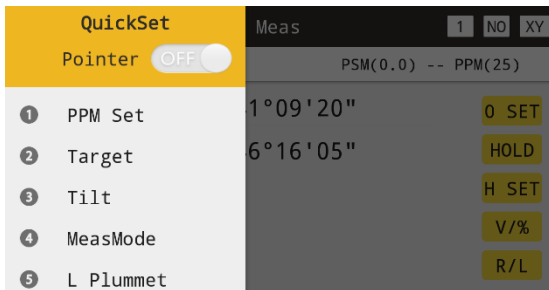

Including the quick set of laser pointer, PPM, target, tilt-sensor, measure mode and laser plummet.

Press ★ or slide the finger from the left side of screen to activate the page of quick-set.

12.1 PPM SET

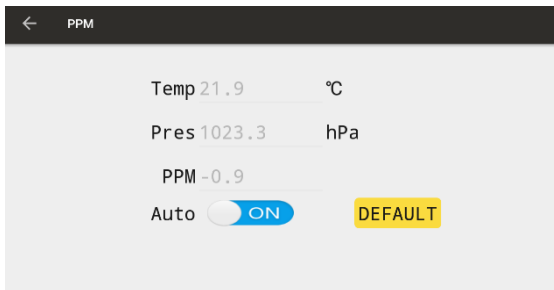

Temp: Temperature of current job.

Pres: Pressure of current job.

PPM: Atmosphere correction value

Auto: On or off the auto correction of temperature-pressure sensor

12.2 TARGET

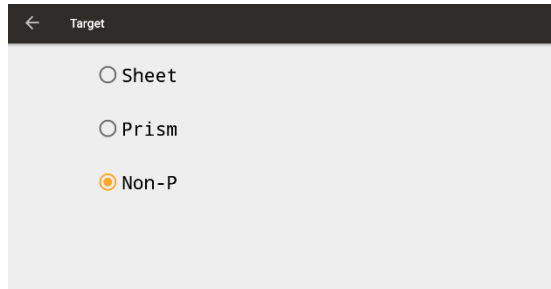

Reflec.: Set the target to reflector sheet

Prism: Set the target to prism

Non-P: Set the target to non-prism

12.3 TILT SENSOR

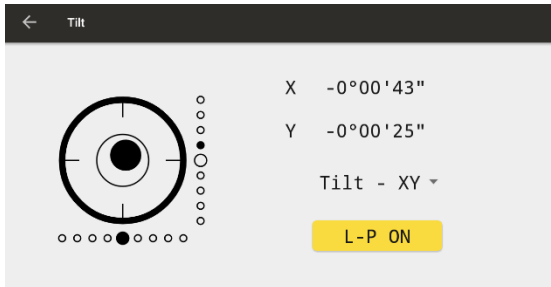

Tilt-XY: On or off the tilt-sensor.

It can be selected among Tilt-X (single-axis), Tilt-XY (dual-axis) or Tilt-Off.

L-P ON: on or off the laser plummet. Click the button to switch between L-P ON and L-P OFF.

12.4 MEASURE MODE

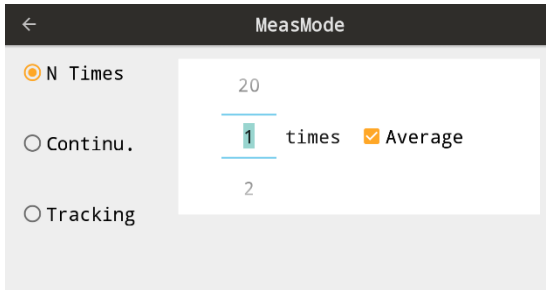

N Times.: Set the measure times as N, and decide whether to calculate the average value or not.

Continu.: Continuous mode.

Tracking: Tracking mode. The accuracy will lower than the other mode, with faster speed.

12.5 LASER PLUMMET



Adjust the illumination level of laser plummet from level 1-5. 5 is the highest level.

13. INSPECTION & ADJUSTMENT

The instrument has passed the procedure of inspection and adjustment before releasing to the market, which ensures that it meets quality requirement. However, after long periods of transportation or the changeable environment, some influences may occur to the internal structure.

Therefore, before the instrument is used for the first time, user should check and adjust the functions we introduced in this session to ensure the precision of the job.

13.1 PLATE VIAL

Inspection

Loosen the horizontal tangent screw, rotate the equipment to ensure that the plate vial is parallel to the direction of foot screw AB. Adjust the screw A/B in opposite direction to move the bubble in the center. Rotate the instrument to 180° to see whether the bubble is in center, if not, the plate bubble needs to be adjusted.

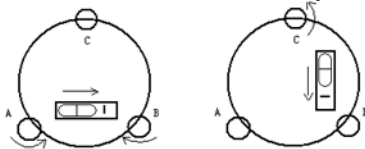

Adjustment

1. If the bubble of the plate vial moves away from the center, bring it half way back to the center by adjusting the screws, which is parallel to the plate vial. Correct the remaining half by adjusting pin.
2. Rotate the instrument in 180° to check whether the bubble is in the center. If not, repeat Step 1.
3. Rotate the instrument in 90° , adjust the third screw. Repeat the steps until the bubble remains in the center in any direction.

13.2 CIRCULAR VIAL

Inspection

It is not necessary to adjust the circular vial, except the bubble is not in the center after the adjustment of plate vial.

Adjustment

If the bubble of the circular vial is not in the center, adjust the bubble to the center by using the adjusting pin or hexagon wrench.

First, loosen the screw opposite to the offset side, and then tighten the other adjusting screw on the offset side, bringing the bubble to the center. When the bubble stays in the center, keep the tightness of the three screws uniformly.

13.3 TILT-SENSOR

Adjust the plate vial at first, leveling the equipment. Then enter the adjustment page of tilt-sensor. Press [SET] to set the sensor as 0 in the current state.

Focusing the same target by HL and HR, and follow the guidance of equipment under Chapter 10.6.

13.4 RETICLE UNIT

Inspection

1. Sight object A after leveling the equipment, lock the horizontal and vertical tangent unit and make sure that target A is in the center of cross-hair.

2. Move object A to the edge of the field of view, point A' by rotating the vertical tangent screw.

3. Adjustment is not necessary if object A moves along the vertical line of the reticle and point A' still in the vertical line.

Otherwise, as picture shown, A' is deviate to the center of the vertical cross-hair, it is necessary to adjust.

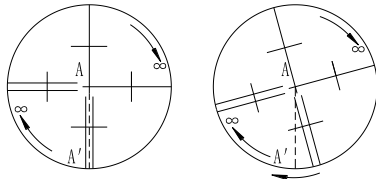

Adjustment

1. Remove the eyepiece cover to expose the four reticle adjusting screws, as picture shown.

2. Loosen the four reticle adjusting screws uniformly by the adjusting pin. Rotate the reticle around the sight line and align the vertical line of the reticle with point A'.

3. Tighten the adjusting screws slightly. Repeat the previous steps to see whether the position is correct.

4. Assemble the eyepiece cover back.

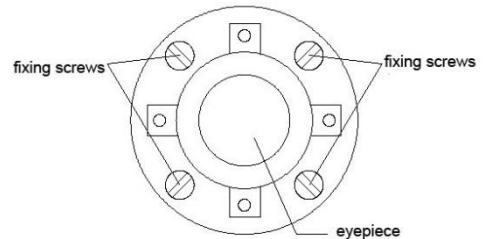

13.5 PERPENDICULARITY BETWEEN SIGHT OF VIEW & HORIZONTAL AXIS (2C)

Inspection

1. Set object A at a far distance at the same height as the instrument, leveling the instrument and turn on the power (eg. $HL=10^{\circ} 13'10''$).
2. Sight object A in horizontal left and read value of HA. (eg. $HR= 190^{\circ} 13'40''$).
3. Loosen the vertical and horizontal tangent unit and rotate the telescope. Sight object A in horizontal right and read the HA.
4. $2C = HL-HR \pm 180^{\circ} = -30'' \geq \pm 20''$, overrange. So it is necessary to adjust 2C.

Adjustment

1. Use the horizontal tangent screw to adjust the reading of HA.
 $HR+C = 190^{\circ} 13'40'' - 15'' = 190^{\circ} 13'25''$
2. Take off the cover of the reticle between the eyepiece and focusing screw. Adjust the two adjusting screws, loosening one screw and tightening the other one. Move the reticle to sight object A exactly.
3. Repeat inspection and adjustment until $|2C| < 20''$. Then replace the cover of the reticle.

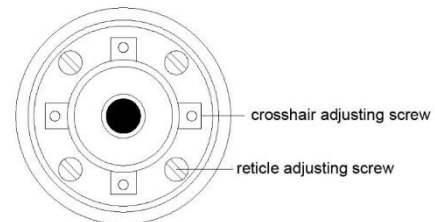

13.6 COMPENSATION OF VERTICAL INDEX DIFFERENCE

Inspection

1. After leveling the instrument, make the EDM parallel with the line connecting the center of the instrument to any one of the screws. Lock the horizontal clamp screw.
2. Switch on the equipment, zero the vertical index. Lock the vertical clamp screw and the instrument will display the vertical angle value.
3. Rotate the vertical tangent unit slowly in either direction about 10mm in circumference, and the overrange message appears. It means that the tilt of vertical axis is larger than $4'$, over the range

of compensation. When rotate the vertical tangent unit in opposite direction back to the original place, the instrument will show the vertical angle again, it means that the compensation of vertical index difference works well.

Adjustment

If the compensation function is not working, please send the instrument back to the authorized agency for maintenance.

13.7 VERTICAL 0 (I ANGLE)

The adjustment of vertical index difference (the so-called i-angle). This item must be adjusted after finishing the adjustment of tilt-sensor and crosshair.

Inspection

1. After leveling the instrument, collimate at any target A in HL. Record the value as L.
2. Rotate the EDM and aim at the target A in HR. Record the value as R.
3. If the vertical 0° in zenith, $I = (L + R - 360^\circ) / 2$. If the vertical 0 in horizon, $I = (L + R - 180^\circ) / 2$ or $(L + R - 540^\circ) / 2$.
5. If $|i| \geq 10''$, it need to reset the Vertical 0.

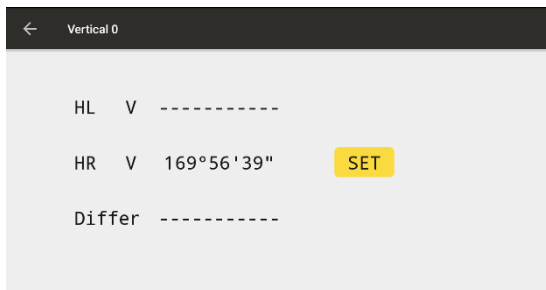

Adjustment

1. Aim at target A in same height with the instrument in HL.
2. Aim at the same target A on HR.
3. After setting the angle in both HL and HR, it will display the index difference, press **[SET]** to set the adjustment.
4. Repeat the inspection steps to check the Index Difference (i angle). If the difference still cannot meet the requirement, please check whether the steps you did are correct. Then reset again.
5. If the Index Difference still fails to meet the requirement after repeated operation, the instrument should be returned to our authorize service center for inspection and repair.

Note: The value of vertical angle is not adjusted and compensated, just for a reference in adjustment.

13.8 CONSTANT K

The Instrument constant has been checked and adjusted in the factory, and $K=0$. It seldom changes and it is suggested to check once or twice in a year.

Inspection

1. Mount and level the instrument on Point A on flat ground. Use the vertical hair to mark Point B and Point C with the distance of 50m on the same line, and collimate the reflector accurately.
2. After setting temperature and pressure value, measure the horizontal distance of AB and AC accurately.
3. Setup the instrument on Point B and center it accurately. Measure the horizontal distance of BC accurately.
4. Then you can get the Instrument Constant:
 $K = AC - (AB + BC)$. The value of K should be close to 0. If $|K| > 5\text{mm}$, the instrument should be strictly inspected on the base alignment, and be

adjusted according to the inspection value.

Adjustment

Set the orientation through the vertical hair to make Point A, B, and C on the same line strictly. There must be a fixed and clear centering mark under the Point B.

The coincidence of the center of the prism and the center of the instrument is very essential to the measuring accuracy. Therefore, it's best to use a tripod or a common-used tribrach on the point B. If we replace it with a three-foot adapter and a tribrach, make sure that they are stable and fixed. It is possible to reduce the inconsistency if we just replace the upper part of the prism and the upper part of the instrument.

13.9 COINCIDENCE BETWEEN SIGHT OF VIEW AND EMITTING AXIS

Inspection

1. Set the reflector 50m away from the instrument. Aim at the center of prism precisely.
2. Activate the laser pointer. Check whether the center of reticle coincides to the laser pointer. If no, please adjust the emitting axis.

Adjustment

If there is a huge deviation between the sight of view and emitting axis, please send the instrument to authorized service center for maintenance.

13.10 LEVELING SCREWS ON TRIBRACH

If any of the leveling screws becomes loose, tighten the adjusting screws on the side of leveling screw appropriately.

14. SPECIFICATIONS

14.1 DISTANCE MEASUREMENT

Model			A1 1"	A1 2"
MAX. RANGE	Prism	Standard	Single: 4km, Triple: 5km	
		Enhanced	Single: 5km, Triple: 6km	
		Sheet	1.2km	
	Non-Prism	Kodak White	1000m	
		Kodak Grey	500m	
ACCURACY	Prism	N Times	1+1ppm	2+2ppm
		Tracking	3+1ppm	5+2ppm
	Sheet	N Times	3+2ppm	
		Tracking	5+2ppm	
	Non-Prism	N Times	D< 300m: 3+2ppm	
			D< 600m: 5+2ppm	
		D> 600m: 10+2ppm		
Tracking	D< 500m: 5+2ppm			
	D> 500m: 10+2ppm			

SPEED	Prism	N Times	< 1.2s	< 1.2s
		Continuous	< 0.7s	< 0.5s
		Tracking	< 0.3s	< 0.25s
	(Enhanced) Prism	N Times	< 1.5s	< 1.5s
		Continuous	< 0.8s	< 0.6s
		Tracking	< 0.4s	< 0.3s
	Sheet	N Times	< 1.0s	< 1.0s
		Continuous	< 0.6s	< 0.5s
		Tracking	< 0.3s	< 0.25s
Non-Prism	Normal: 0.5-3s. weak signal: < 10s.			
OTHERS	Distance Unit	M, FT		
	Basic Frequency	70-150MHz		
	Constant	Manual Input,		
	Atmos. Correction	Auto Correction		

14.2 ANGLE MEASUREMENT

ANGLE MEASUREMENT	Accuracy	1"/2"	2"
	Minimum Reading	0.1"/1"	1"
	Measure Method	Absolute Encoding	
	Diameter of Disk	79mm	
	Angle Unit	Degree, Gon, Mil	
	Vertical 0	H0, V0	

14.3 HARDWARE

TELESCOPE	Image	Erect
	Magnification	30x
	Effective Aperture	45mm (DTM: 47mm)
	Resolution Ratio	3"
	Field of View	1° 30'
	Minimum Focus	1.5m
	Tube Length	152mm

VIAL	Plate Vial	30"/2mm
	Circular Vial	8"/2mm
SENSOR	System	Dual-axis
	Compensate Range	± 3'
	Resolution Ratio	1"
PLUMMET	Laser Level	Level II, red laser
	Accuracy	1.5mm (InsHt 1.5m)
	Diameter	2.5mm (InsHt 1.5m)
BATTERY	Type	7.4V, Li-ion battery
	Working Hours	8 hours
OTHERS	Data Communication	RS-232, USB, Flashdisk, Bluetooth
	Display Screen	LCD, graphic display
	Working Temperature	-20°C to + 50°C
	Dimension	206*200*353mm
	Weight	6.0kg

14.4 ANDROID SYSTEM

MEMORY	ROM	16GB
	RAM	2GB
	CPU Version	MT6735
FEATURES	Display Unit	5inch, 118*65mm
	Input Method	Touch screen
	GPS	Available
	Recorder	Available
NETWORK	GSM 850/900/1800MHz CDMA/EVDO BCO WCDMA Band 1/2/5/8 TD-SCDMA Band 34/39 TDD-LTE Band 38/39/40/41 FDD-LTE Band 1/3	
SYSTEM	Android 5.1 (until 2018.12)	

15. ERROR CODE

CODE	DESCRIPTION	SOLUTION
ERROR 01-06	Problems in angle measurement system	Restart equipment. If the error code still remains, please
ERROR 31-36	Problems in distance measurement system	contact your authorized agency

16. SAFETY GUIDE

16.1 INTERNAL DISTANCE METER (VISIBLE LASER)

Warning

The total Station is equipped with an EDM of Laser Class 3A/III a and it is verified by these labels as follows:

There's an indication label "CLASS III LASER PRODUCT" above the vertical clamp screw on Face Left as well as on the Face Right.

The product is classified as Class 3A laser product, according to the standards as follows:

IEC60825-1:2001 "SAFETY OF LASER PRUDUCTS"

The product is classified as Class III a laser product according to the standards as follows:

FDA21CFR ch.1 § 1040:1998 (U.S. department of Health and Human Services, Code of Federal

Regulation)

Class 3A/III a laser product: It is harmful to observe the laser beam continuously. Users should avoid staring at the laser directly. It can reach as much as 5 times the emitting limit of Class 2 / II with a wavelength between 400nm and 700nm.

Warning

It is harmful to continuously look straight at the laser beam.

Prevention

Do not stare at the laser beam, or point the laser beam at others. Reflecting laser beam is also valid.

Warning

When the laser beam emits on prism, mirror, metal surface, window, it might be dangerous to look directly at the reflecting light.

Prevention

Do not stare at the direction which the laser beam is reflected. When the laser is turned on (under distance measure mode), do not look at it near the optical path or the prism. It is only allowed to observe the prism through the telescope of the total station.

Warning

It is dangerous to make improper use of the Class IIIa laser equipment.

Prevention

To avoid incurring harm, all the users should take safety precautions, and must make sure that everything is under control within the distance

that might bring dangers (according to IEC60825-1:2001)

There are explanations of some principle points of related standard as follows:

Class 3R laser product is used in outdoors and construction site (measuring, defining alignment, leveling, etc.). The laser equipment can only be installed, adjusted and operated by those persons who have taken related training course and got the authentication.

- a. Set related laser warning marks on site.
- b. Prevent anyone from looking straight at the laser beam directly or through optic instrument.
- c. To avoid the harm brought by laser, users should block the laser beam at the end of the working route. When the laser beam passes through the restricted area (harmful distance*), and there are persons taking activities, users

must stop the laser beam in time.

d. The optical path of the laser beam should be set higher or lower than the line of sight.

e. When the laser instrument is not in use, users should keep it well. It is not allowed for operation unless the user is authenticated.

f. Prevent the laser beam from accidentally emitting at mirror, metal surface, window, etc. Especially pay attention to the surface of plane mirror or concave mirror.

* Harmful distance suggests that the maximum distance from the start point of the laser beam to the point which the laser beam is weakened to a certain degree that doesn't harm people.

The internal distance measure product which is equipped with a Class3R/III a Laser Product has a harmful distance of 1000m (3300ft). Beyond this distance, the laser strength is weakened to Class I (It is not harmful to look straight at the laser beam

16.2 LASER PLUMMET

The internal laser plummet sends out a ray of red visible laser beam from the bottom of the instrument.

This product is classified as Class 2/II laser product.

Class 2 laser product is in accordance with the following standard:

IEC 60825-1:1993 "SAFETY of LASER PRODUCTS"
EN 60825-1:1994+A II:1996 "SAFETY of LASER PRODUCTS"

Class II laser product is in accordance with the following standard:

FDA21CFR ch.1 § 1040:1998 (U.S. Department of Health and Human Services, Code of Federal Regulations)

Class 2/II Laser Product:

Do not stare at the laser beam or point it at others. Users should prevent the laser beam and the strong reflecting light from impinging into eyes so as to avoid incurring harm

APPENDIX A - DATA FORMAT

Raw Data

JOB	job name, description
DATE	date, time
NAME	name of the job creator
INST	serial number of the total station
UNITS	units in use: m/inch, dms/gon
SCALE	grid factor, scale, altitude
ATMOS	temperature, pressure
STN	Station ID, instrument height, code
XYZ	coordinate

BKB	backsight point, backsight angle, azimuth
SS	point name, target height, code
HV	horizontal angle, vertical angle
HD	horizontal angle, vertical angle, height difference
SD	horizontal angle, vertical angle, slide distance
OFFSET	radial offset, tangential offset, plummet offset

Coordinates Data

The data in below formats can be transferred to the computer.

1. Pt, N, E, Z, code
2. Pt, E, N, Z, code
3. Pt, code, N, E, Z
4. Pt, code, E, N, Z

Code Data

1. Horizontal Alignment

name	name of the road
start	start chainage
line	the length of the straight line
arc	radius of the circle, length of the curve
spiral	radius, length

2. Vertical Alignment

gcp	mile, elevation, length
-----	-------------------------

DXF File

Refer to Standard R12.

1. All points with the same code will be on the same layer.
2. All the lines are on the same layer.
3. All points without a code will be on the default layer.

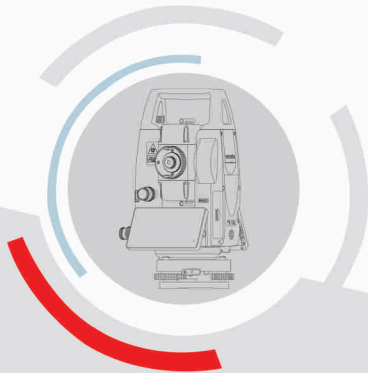

Dealer Info

SOUTH SURVEYING & MAPPING TECHNOLOGY CO., LTD.

Email: mail@southsurvey.com export@southsurvey.com impexp@southsurvey.com euoffice@southsurvey.com
Http: [//www.southinstrument.com](http://www.southinstrument.com) www.southsurvey.com